

STANDARD MATERIALS AND CONSTRUCTION

FRAME: .125" thick (nominal) extruded aluminum, 6063-T52/T6 alloy. Welded construction.

BLADE: .081" thick (nominal) extruded aluminum, 6063-T52/T6 alloy, mechanical fastening construction. Blades approximately 4" on centers.

LOUVER FACE: Full width sill with head and blades contained within jambs.

SCREEN: (When indicated, in a removable frame.)

- or- ½" flattened aluminum (.051" thick),
- or- ½" sq. mesh, intermediate double-crimped aluminum wire, .063" dia.,
- or- ¼" mesh, .011" dia. aluminum wire, insect screen.

FINISH: Mill

Withstands pressures up to 180± PSF.

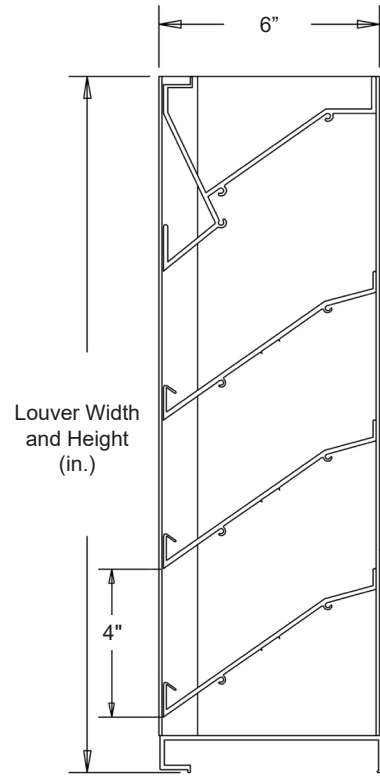

Not to scale.

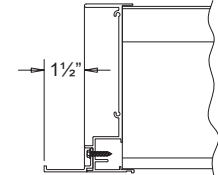

Optional Flange Frame (Jamb shown)

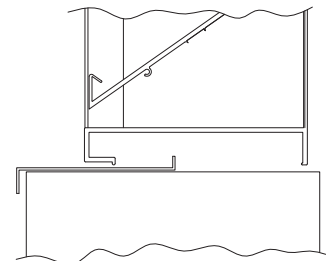

Optional Extended Sill

TEST METHODS

Miami-Dade County Florida Test Protocols:

- TAS (PA) 201
- TAS (PA) 202
- TAS (PA) 203

OPTIONS

Finish - Baked Enamel, Kynar, Anodize

Extended Sill Flashing - available with Mill, Painted, or Anodized finishes.

NOTES

1. ½" nominal deduction will be made to the opening size given.
2. Panels over 48" wide will have a 2" x 2" x ¼" vertical interior blade support angle at approximate center of panels.
3. Approximate shipping weight is 6.0 lbs./sq.ft.

LOUVER SIZES

Min Panel	Max Single Panel
12"W x 12"H	96"W x 96"H

Windload requirements may limit panel sizes.

This louver has been tested to **AMCA Standard 540 for Wind Borne Debris Impact Resistance**. See Page 2 for seal and listing information.

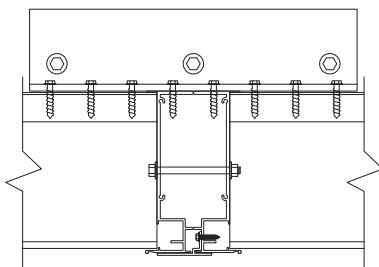

Standard Vertical Mullion

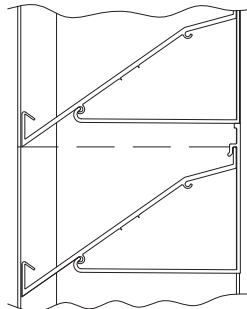

Standard Horizontal Mullion

Item #	Qty	Width	Height	Width	Height	Mullion	Type	Location		
		Opening Size		Louver Size			Screens			
Arch. / Eng. :						EDR:		ECN:		Job:
Contractor:										
Project:						Date:		DWN:		DWG:

PERFORMANCE DATA

Pressure Drop: .14 in. w.g. at 1000 fpm (intake)

Free Area: 9.24 sq.ft. (0.858 sq.m.) = 58% for 48"W x 48"H sample tested in accordance with AMCA Standard 500-L.

Beginning Point of Water Penetration: Above 1250 fpm (11,550 cfm)

Ratings do not include effects of a screen.

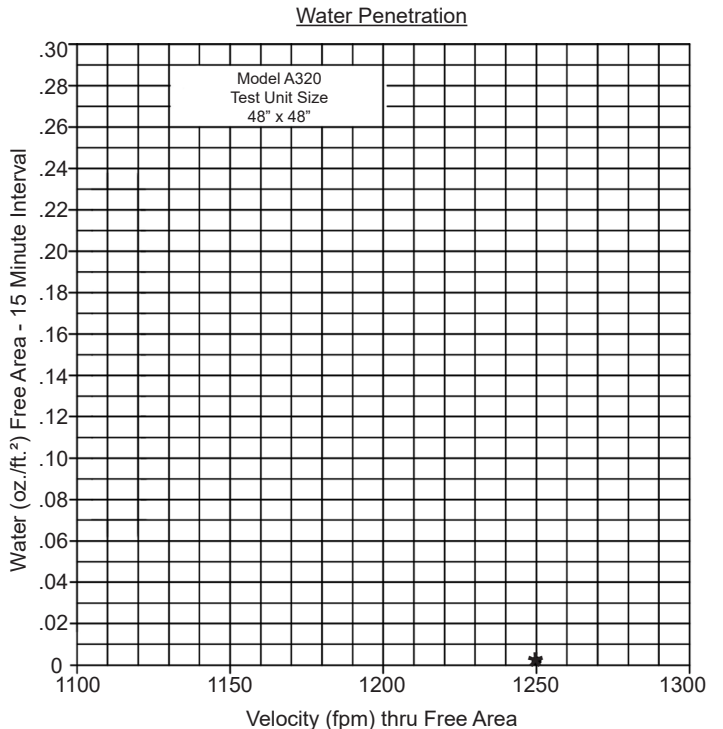
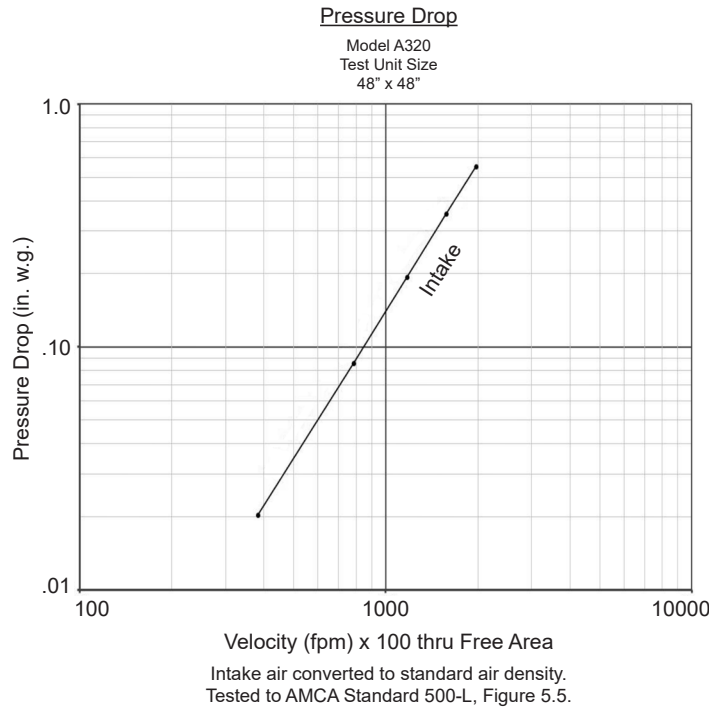

* AMCA Standard 500 limits testing of Water Penetration to either a maximum velocity of 1250 FPM or 2.5 ounces of water per square foot of louver Free Area.

* The Beginning Point of Water Penetration is above 1250 FPM through the Face Free Area of the louver.

Free Area (sq.ft.)

		Width in. (mm)							
		12" (305)	24" (610)	36" (914)	48" (1219)	60" (1524)	72" (1829)	84" (2134)	96" (2438)
Height in. (mm)	12" (305)	0.18 (0.016)	0.43 (0.039)	0.69 (0.064)	0.94 (0.087)	1.16 (0.107)	1.42 (0.131)	1.67 (0.155)	1.93 (0.179)
	24" (610)	0.69 (0.064)	1.70 (0.157)	2.70 (0.250)	3.71 (0.344)	4.59 (0.426)	5.59 (0.519)	6.60 (0.613)	7.60 (0.706)
	36" (914)	1.21 (0.112)	2.96 (0.274)	4.72 (0.438)	6.47 (0.601)	8.01 (0.744)	9.76 (0.906)	11.52 (1.070)	13.27 (1.232)
	48" (1219)	1.72 (0.159)	4.23 (0.392)	6.73 (0.625)	9.24 (0.858)	11.43 (1.061)	13.93 (1.294)	16.44 (1.527)	18.94 (1.759)
	60" (1524)	2.24 (0.208)	5.49 (0.510)	8.75 (0.812)	12.00 (1.114)	14.85 (1.379)	18.11 (1.682)	21.36 (1.984)	24.62 (2.287)
	72" (1829)	2.75 (0.255)	6.76 (0.628)	10.72 (0.995)	14.77 (1.372)	18.27 (1.739)	22.28 (2.069)	26.28 (2.441)	30.29 (2.814)
	84" (2134)	3.72 (0.303)	8.02 (0.745)	12.78 (1.187)	17.53 (1.628)	21.69 (2.015)	26.45 (2.457)	31.20 (2.898)	35.96 (3.340)
	96" (2438)	3.78 (0.351)	9.29 (0.863)	14.79 (1.374)	20.30 (1.885)	25.12 (2.333)	30.62 (2.844)	36.13 (3.356)	41.63 (3.867)



Visit our CRP Page for information on all our AMCA-rated products.

Air Balance certifies that the Model A320 shown herein is licensed to bear the AMCA seal. The ratings shown are based on tests and procedures performed in accordance with AMCA Publication 511 and comply with the requirements of the AMCA Certified Ratings Program. The AMCA Certified Ratings Seal applies to Water Penetration and Air Performance Ratings only.



540 IMPACT RESISTANT LOUVER
Basic Protection Level D

See www.AMCA.org for all certified or listed products

This label does not signify AMCA airflow performance certification.

Air Balance certifies that the Model A320 shown herein is approved to bear the AMCA Listing Label. The ratings shown are based on tests and procedures performed in accordance with AMCA Publications and comply with the requirements of the AMCA Listing Label Program.

The AMCA Listing Label applies to Wind Borne Debris Impact Resistant Louvers.

STANDARD BOXED FRAME MODEL A320

INSTALLATION INSTRUCTIONS

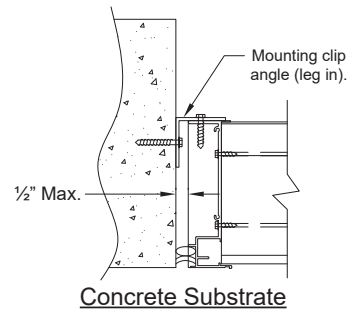
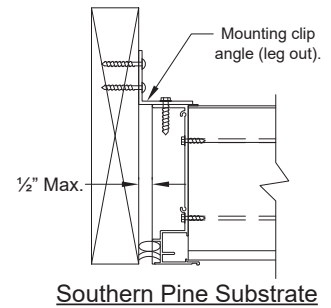
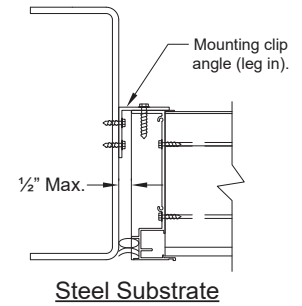
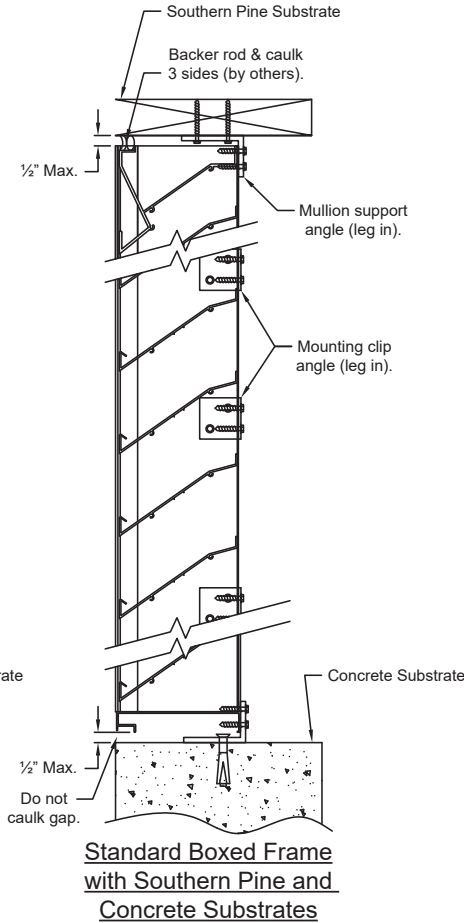
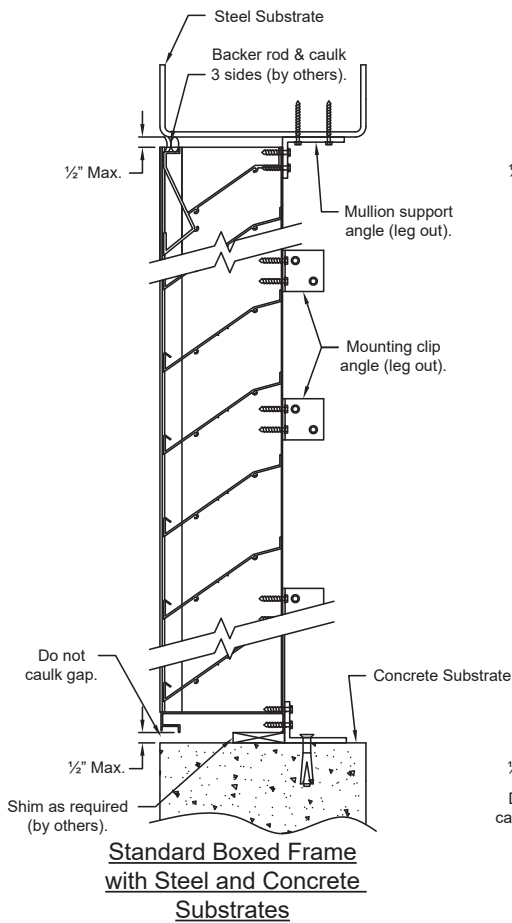

NOTES

1. Mounting clip angles and mullion support angles can be installed with “legs in” or “legs out” for any approved substrate.
2. “Legs out” is the standard construction, “legs in” is optional.
3. Use shims to obtain uniform clearance between the louver and the louver opening on all sides. Shims are by others.
4. Shims under sill pans must allow enough space to insert “leg in” option into the opening.

FLANGED FRAME MODEL A320

INSTALLATION INSTRUCTIONS

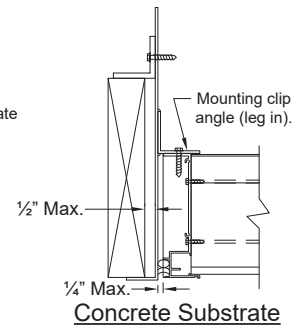
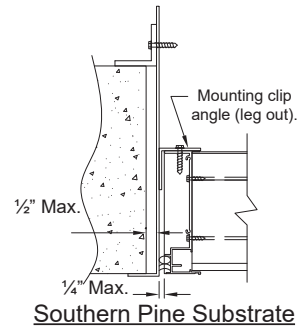
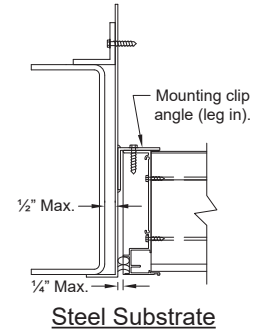
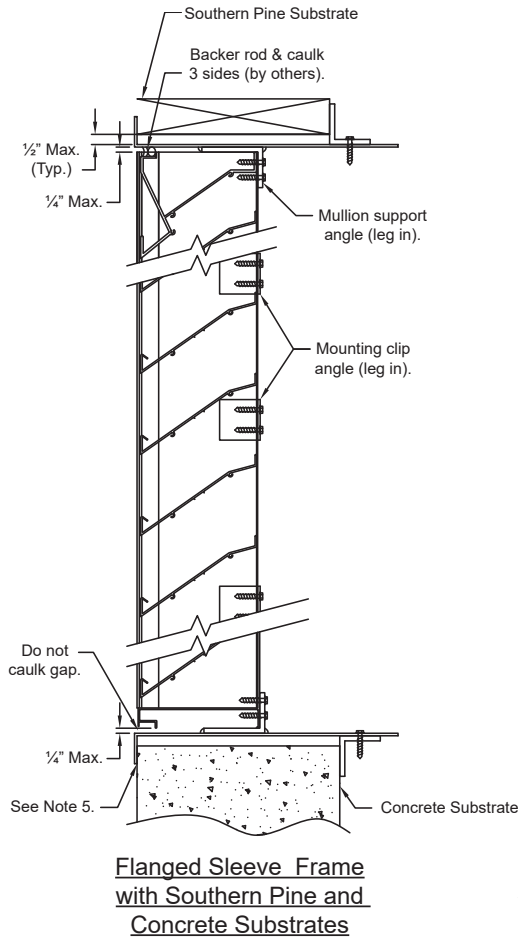
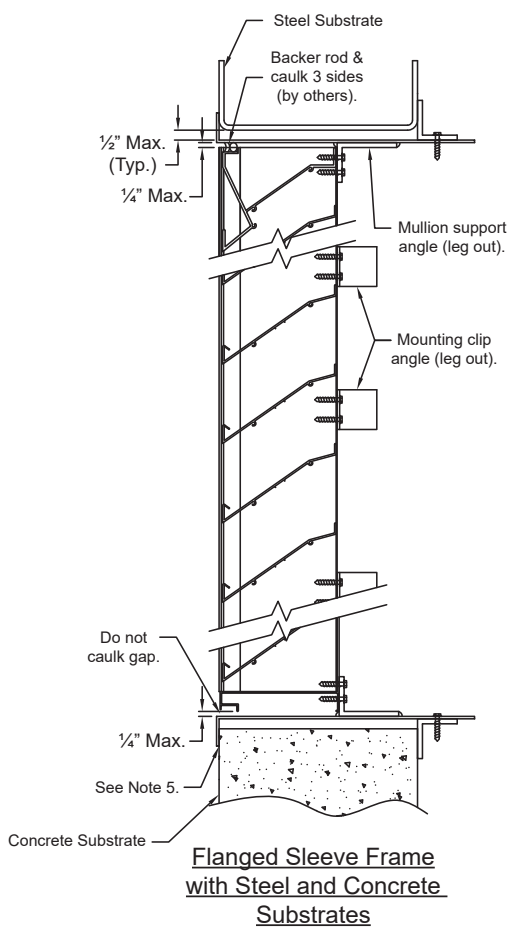

NOTES

1. Mounting clip angles and mullion support angles can be installed with “legs in” or “legs out” for any approved substrate.
2. “Legs out” is the standard construction, “legs in” is optional.
3. The flanged sleeve can be used with any approved substrate.
4. Use shims to obtain uniform clearance between the louver and the louver opening on all sides. Shims are by others.
5. Sealant/caulk between flanged angle sleeve and substrate (typ. 4 sides) by installer.
6. Two mounting angles run the full height and length of louver.

TAS-100 APPROVED FLANGED FRAME MODEL A320 WITH DAMPER

INSTALLATION INSTRUCTIONS

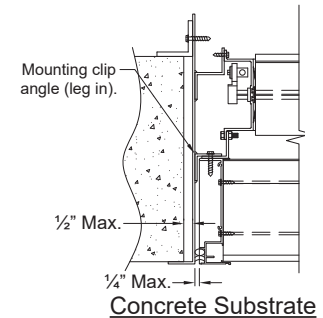
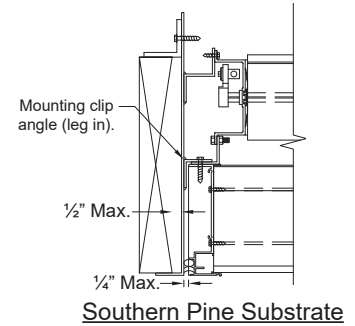
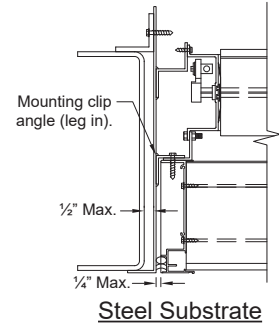
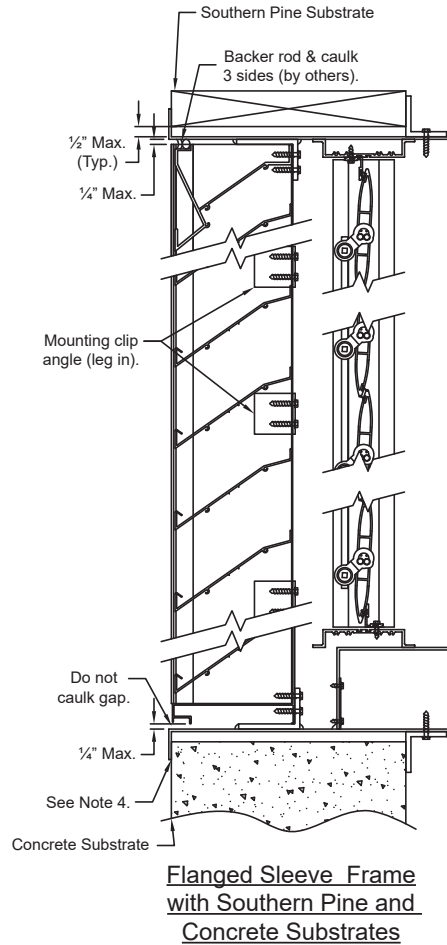
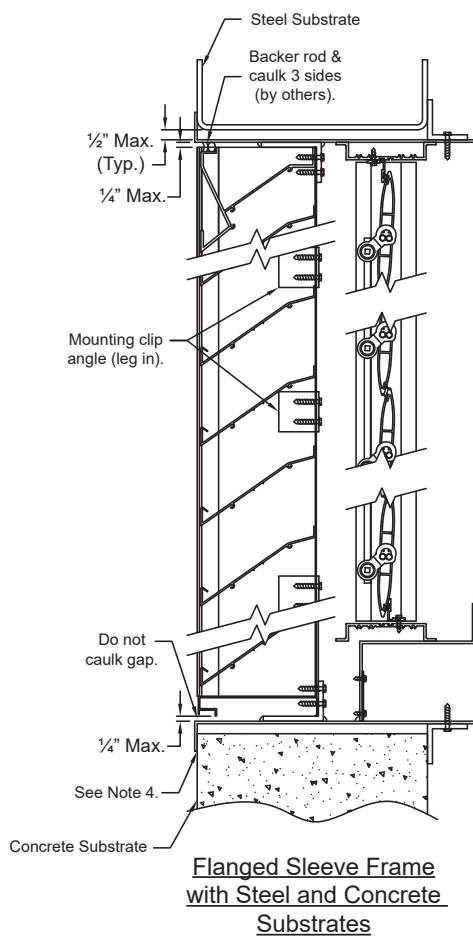

NOTES

1. Mounting clip angles and mullion support angles can be installed with “legs in” or “legs out” for any approved substrate.
2. The flanged sleeve can be used with any approved substrate.
3. Use shims to obtain uniform clearance between the louver and the louver opening on all sides. Shims are by others.
4. Sealant/caulk between flanged angle sleeve and substrate (typ. 4 sides) by installer.
5. Two mounting angles run the full height and length of louver.